



MODEL MBCB 56 MICHAEL BYRNE EXTREME HEAVY DUTY

Michael Byrne Manufacturing Co, Inc.

CRADLE BORING MACHINE

Pipeline Jobs are not for the faint of heart, the Men and Women that thrive in this environment are throwbacks to the earlier pioneers with "Rugged" as their middle name.

Michael Byrne Manufacturing has the machine for those pioneering individuals coupled with today's technology and safety features.

The Michael Byrne MBCB56 is a machine to handle all types of rugged terrain and environments.

The MBCB56 is powered by a CAT 350 HP water cooled diesel engine, and proven auger boring specific designed gearboxes to transmit the torque needed for those long pushes. A durable planetary winch provides the pulling force needed to complete your bore.

This machine rivals the heavy duty track machines used on long, large diameter bores.

Call Michael Byrne Manufacturing to get your pipeline installed on-time, on-line, and on-budget.



MODEL MBCB 56 MICHAEL BYRNE EXTREME HEAVY DUTY CRADLE BORING MACHINE

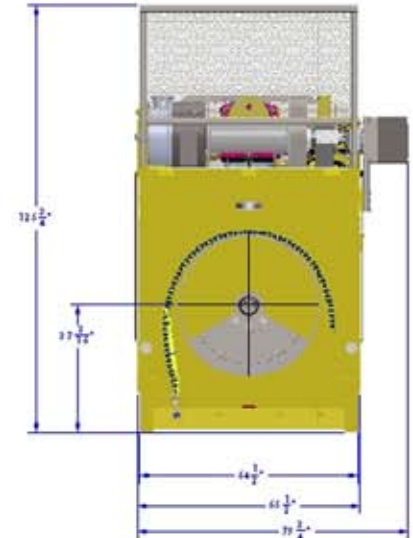
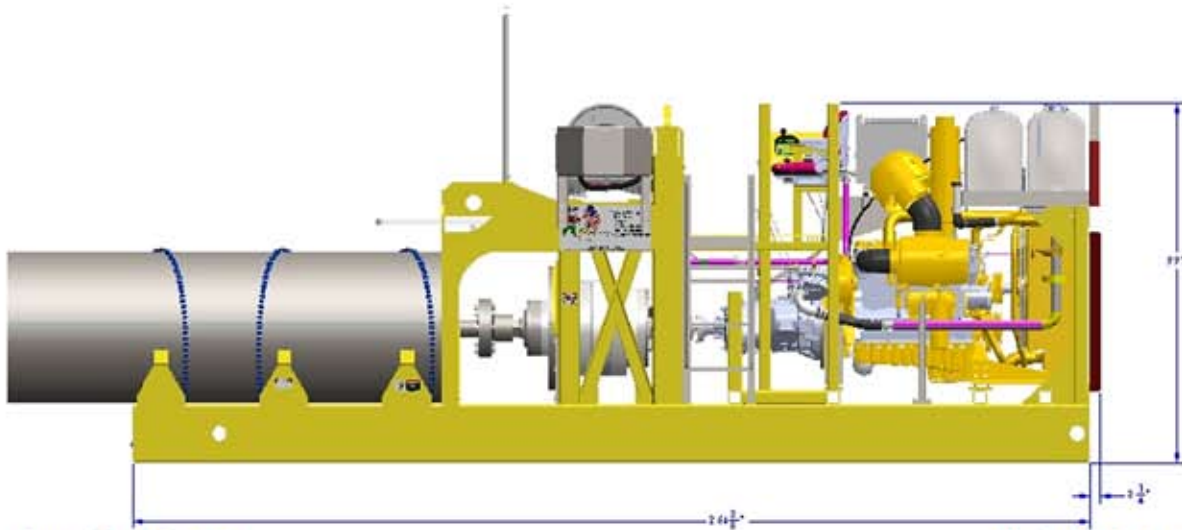

Power Train System

Engine: CAT 350 HP (261 Kw) @ 1800 Rpm @ Max Torque of 1,094 Ft Lbs (1,483 Nm)

Fuel Capacity: 45 U.S. Gallons (170.25 Liters)

TRANSMISSION: Eaton Fuller

1st Gear	DO NOT USE!!!
2nd Gear	8.19
3rd Gear	6.05
4th Gear	4.46
5th Gear	3.34
6th Gear	2.48
7th Gear	1.83
8th Gear	1.36
9th Gear	DO NOT USE!!!
10th Gear	DO NOT USE!!!
Reverse	DO NOT USE!!!
Reverse	2.72

Planetary Gearbox Ratio 25.41 : 1

Auger Drive: 5" Hex Std with 3" & 4" Hex adapters available (12.7 cm)

Working Range: 12" to 56" (30.48 cm to 142.24 cm)

Machine Torque and Speed Max

Transmission Ratios	Planet Drive Ratio	Max Torque Ft-Lbs	Max Torque N-M	Output Rpm
1st Gear	11.06	DO NOT USE!!!	DO NOT USE!!!	DO NOT USE!!!
2nd Gear	8.19	214,010	290,183	8.65
3rd Gear	6.05	158,090	214,360	11.71
4th Gear	4.46	116,543	158,024	15.88
5th Gear	3.34	87,276	118,341	21.21
6th Gear	2.48	64,804	87,870	28.56
7th Gear	1.83	47,819	64,839	38.71
8th Gear	1.36	35,538	48,187	52.09
9th Gear	1.00	DO NOT USE!!!	DO NOT USE!!!	DO NOT USE!!!
10th Gear	0.75	DO NOT USE!!!	DO NOT USE!!!	DO NOT USE!!!
Reverse	12.12	DO NOT USE!!!	DO NOT USE!!!	DO NOT USE!!!
Reverse	2.72	71,075	96,373	26.04

Hydraulic System

Pressure 3,000 PSI (206.9 Bar)
 Pump Type Axial Piston with Load Sensing
 Gallon per Minute 60 GPM (227 Liters)
 Winch 130,000 Lbs Single Line Max @ 2,500 Psi (172.4 Bar) with variable pull speed, 350 Ft Cable. 3/4" or 7/8" Cable, air actuated clutch and air actuated drum brake to prevent bird nesting. Greater Pulling Force is achieved by increasing the number of part lines.

Suction Strainer 140 Mesh Screen
 Return Filter 10 Micron Replaceable Element
 Heavy Duty Hydraulic Oil Cooler : Oil cooling provided to allow optimized performance of machine in extreme conditions.

Weights (Approx.) (US Customary Units)

Frame Assembly 23,000 Lbs.

Dimensions (US Customary Units)

Centerline of Bore to Bottom of Track : 37-3/16"
 Machine Height : 125-3/4"
 Machine Width : 65-1/2" / @ Winch 79-3/4"
 Frame Length : 264-3/8" Ft

Weights (Approx.) (Metric Units)

Frame Assembly 10,433 Kg

Dimensions (Metric Units)

Centerline of Bore to Bottom of Track : 94.5 cm
 Machine Height : 319.4 cm
 Machine Width : 166.4 cm / @ Winch 202.3 cm
 Base Track Length : 671.5 cm