

D60/72-1.5M

POWER TRAIN SYSTEM

- ENGINE: JD-250 HP@2200 RPM WATER COOLED, FINAL TIER 4

FUEL CAPACITY

- 70 U.S. GALLONS

TRANSMISSION:

- FS-5205A

RATIOS:

- 1ST GEAR 7.52:1
- 2ND GEAR 4.35:1
- 3RD GEAR 2.54:1
- 4TH GEAR 1.52:1
- 5TH GEAR 1.00:1
- REVERSE 6.27:1

PLANETARY GEARBOX:

- B16-B13, WITH PUSH PULL THRUST BEARING PACKAGE
- RATIO 47.25:1

AUGER DRIVE:

- 4" & 5" HEX

WORKING RANGE:

- WORKING RANGE: 24" TO 72" EARTH BORING; PIPE JACKING

Options:

- BRAKE/DRIVE SYSTEM (NOT SHOWN)
- AKKERMAN GUIDED BORE "READY" (NOT SHOWN)

MACHINE TORQUE AND SPEED MAX:

TRANSMISSION	RATIOS	PLANET DRIVE RATIO	MAX TORQUE, 710 FT-LBS @1600 RPM	OUTPUT @2200 RPM
1ST GEAR	7.52	47.25	252,277	6.2
2ND GEAR	4.35	47.25	145,931	10.7
3RD GEAR	2.45	47.25	82,191	19.0
4TH GEAR	1.48	47.25	49,650	31.5
5TH GEAR	1.00	47.25	33,547	46.6
REVERSE	6.27	47.25	210,342	7.4

MICHAEL BYRNE MANUFACTURING

1855 EARTH BORING ROAD, P.O. BOX 444 MANSFIELD OHIO 44901

WWW.BYRNEGROUP.COM

OFFICE: (419) 525-1214

TOLL FREE: (800) 613-7206

FAX: (419) 525-2389

WEIGHTS:

- TOP BASE: 18,100 LBS
- BOTTOM BASE: 15,400 LBS
- MASTER TRACK: 7,630 LBS
- EXTRA TRACK: 4,200 LBS
- MASTER RING (60): 5,100 LBS
- MASTER RING (72): 6,600 LBS
- MASTER SADDLE: 840 LBS

HYDRAULIC SYSTEM

- PRESSURE.....5,800 PSI
- PUMP TYPE AXIAL PISTON WITH LOAD SENSING
- 2x PUMP, 88 GPM
- CYLINDERS (4) 9" BORE X 36" STROKE
- SUCTION STRAINER...100 MESH SCREEN
- PRESSURE FILTER.....10 MICRON REPLACEABLE ELEMENT
- RETURN FILTER.....10 MICRON REPLACEABLE ELEMENT
- HEAVY DUTY HYDRAULIC OIL COOLER

MICHAEL BYRNE MANUFACTURING

MBM
international

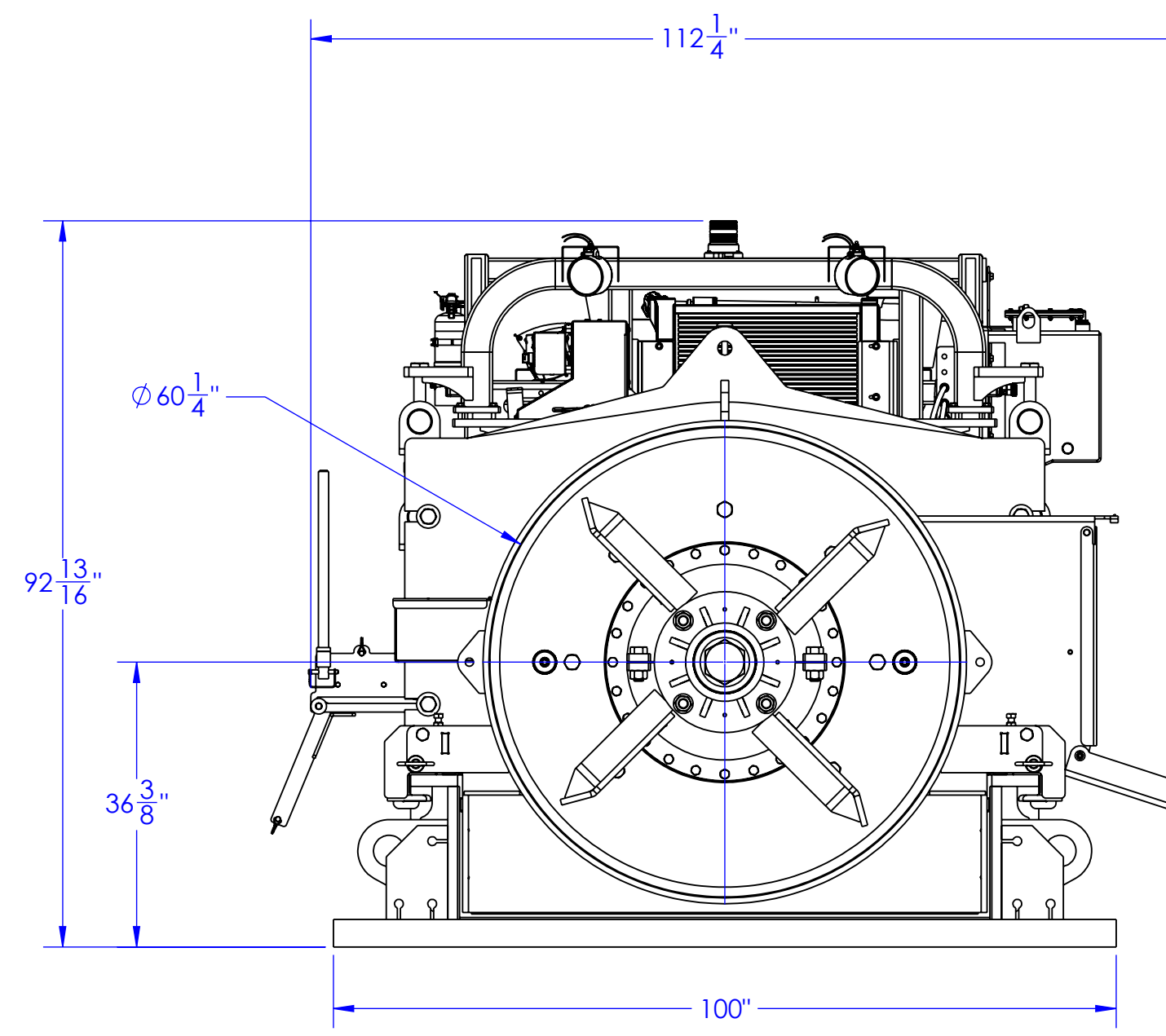
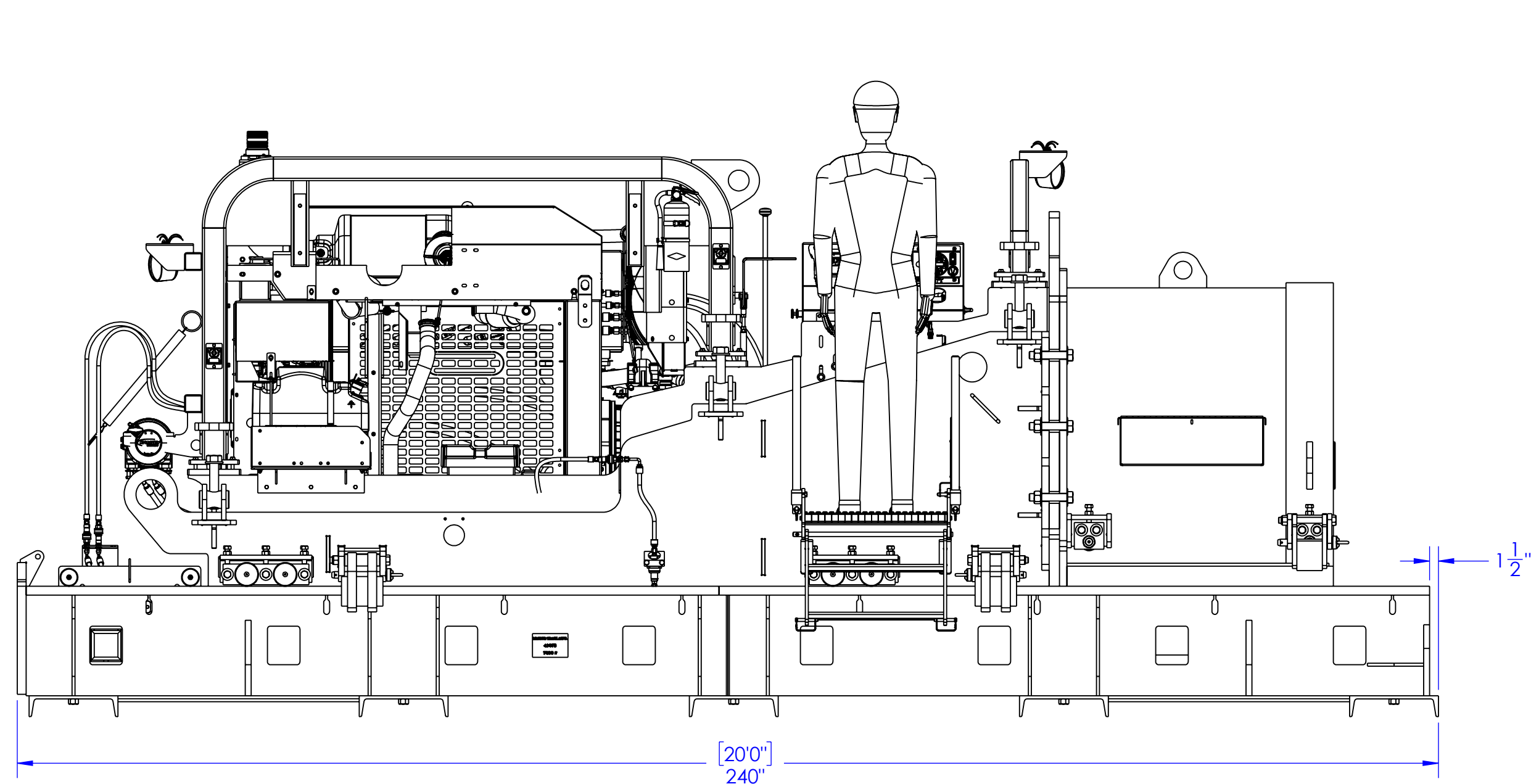

60" MASTER RING SHOWN

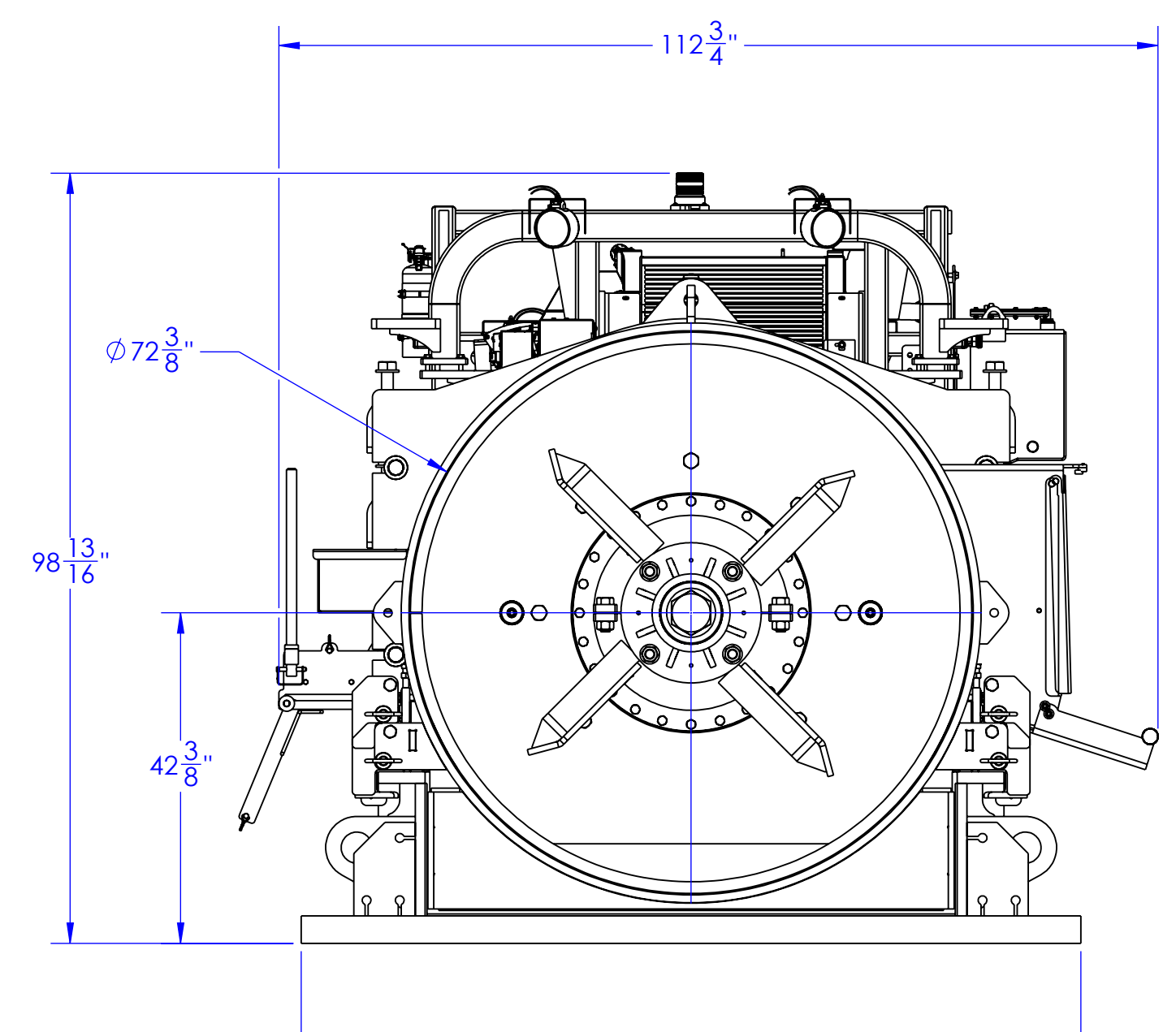

72" MASTER RING SHOWN