

**Power Train System**

Engine: Deutz 3.6T T4F 75Hp @ 2200 Rpm Water cooled.

Fuel Capacity: 28 U.S. Gallons

**TRANSMISSION: T-18**

**RATIOS**

1st Gear 6.32:1  
 2nd Gear 3.09:1  
 3rd Gear 1.69:1  
 4th Gear 1.00:1  
 Reverse 7.44:1

**Planetary Gearbox Ratio 54:1** Fairfield S20 Gear Box

Auger Drive: 3" or 4" Hex & 5" Hex  
 Working Range: 12" to 36" Earth Boring ; Pipe Jacking

**Machine Torque values below are at 2200 RPM**

**(Max engine torque is at 1700 rpm for a 22% torque rise over figures below)**

Transmission Ratios	Planet Drive Ratio	Max Torque Ft-Lbs	Max Torque In-Lbs	Output Rpm
1st Gear 6.32	54	64,843	778,118	7.6
2nd Gear 3.09	54	31,703	380,440	13.2
3rd Gear 1.69	54	17,339	208,073	24.1
4th Gear 1.00	54	10,260	123,120	40.7
Reverse 7.44	54	76,334	916,012	5.5

D36-500

**MICHAEL BYRNE MANUFACTURING**

1855 EARTH BORING RD., PO BOX 444 MANSFIELD, OH 44901

www.byrnegroup.com

Office: (419)525-1214

Toll Free: (800) 613-7206

Fax: (419)525-2389

**Weights**

Top Base : 7,500 Lbs  
 Bottom Base : 6,200 Lbs  
 Master Track : 3,300 Lbs  
 Extra Track: 2,100 Lbs  
 Master Ring : 2,300 Lbs  
 Master Saddle: 340 Lbs

**Hydraulic System**

Pressure 4,350 PSI  
 Pump Type Piston Pump with Load Sensing  
 Gallon per Minute 30 GPM  
 Cylinders (3) 7" Bore x 36" Stroke 3 **Cylinder Max Thrust 500,000 Lbs.**  
**2 Cylinder max thrust 330,000**  
 Suction Strainer 100 Mesh Screen  
 Pressure Filter 10 Micron Replaceable Element  
 Return Filter 10 Micron Replaceable Element

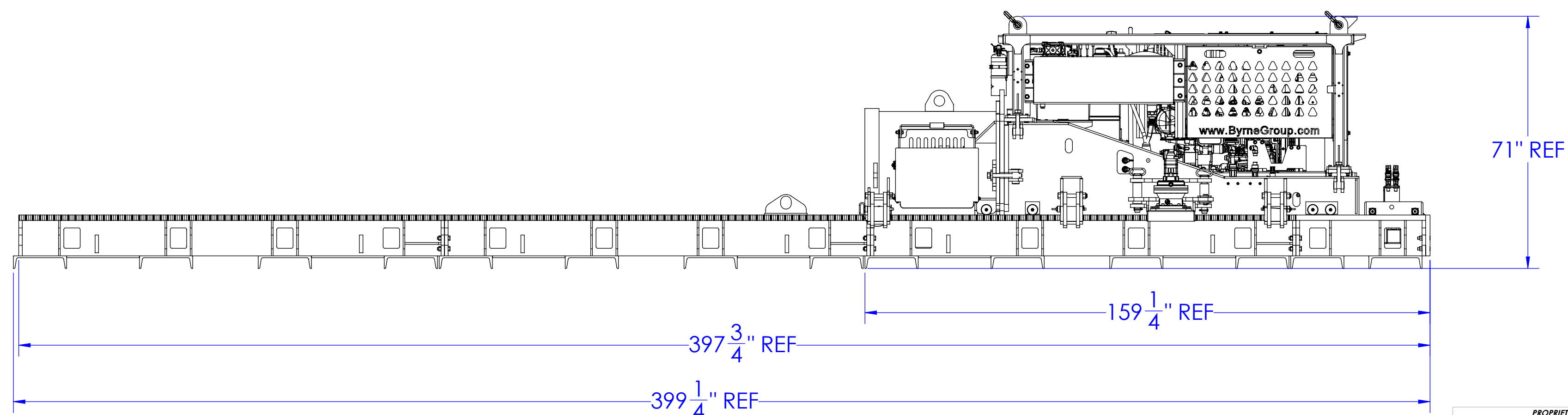
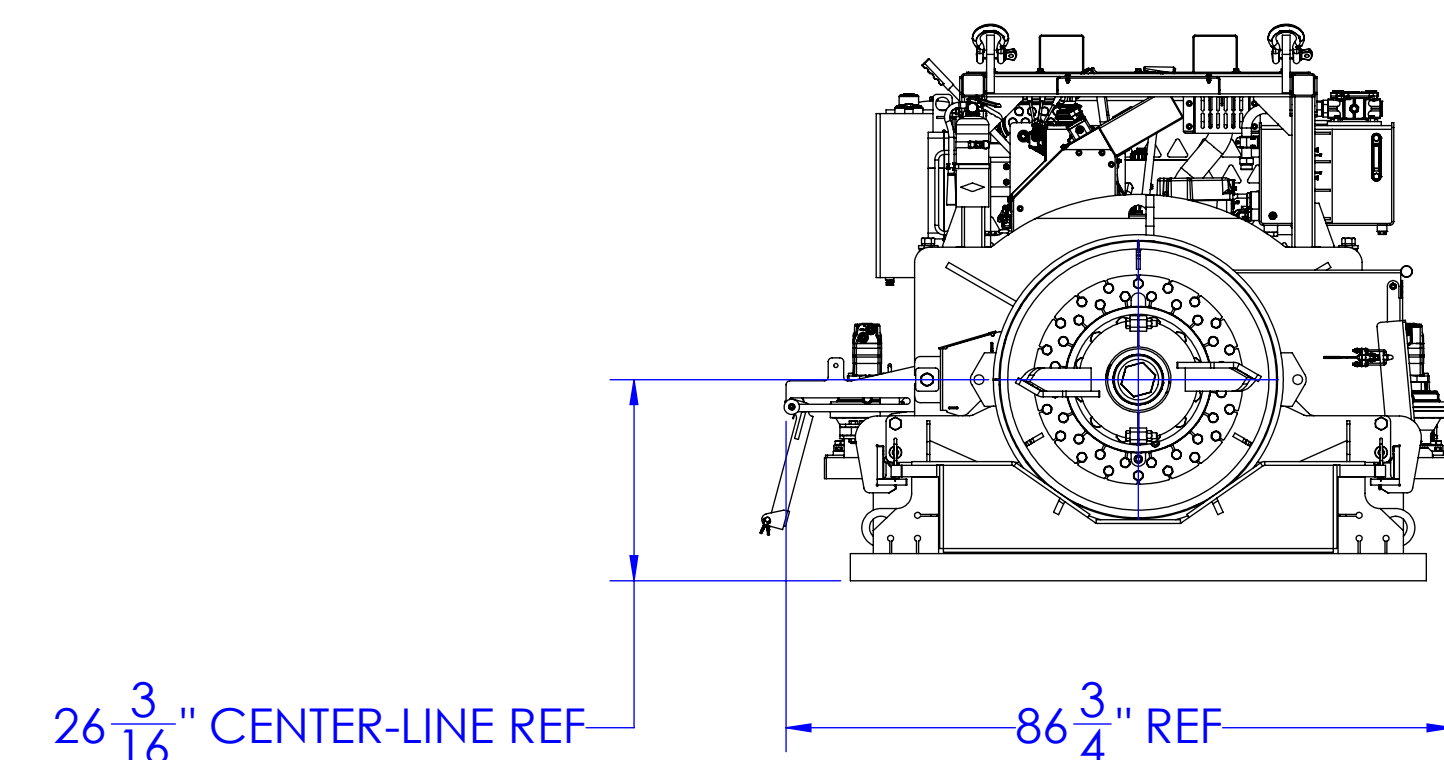
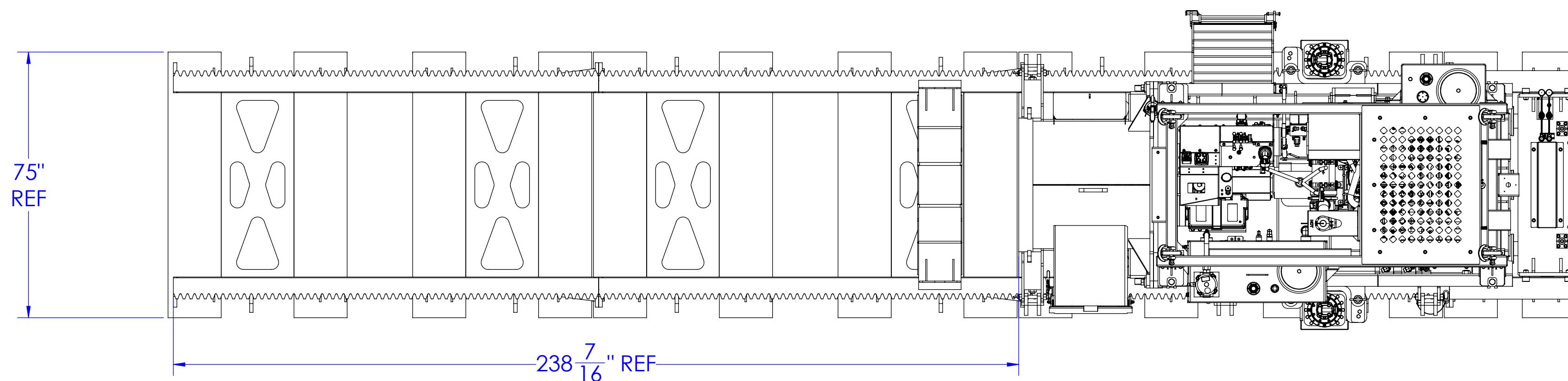

PROPRIETARY AND CONFIDENTIAL  
 THE INFORMATION CONTAINED IN THIS  
 DRAWING IS THE SOLE PROPERTY OF  
 Michael Byrne Mfg Co. ANY  
 REPRODUCTION IN PART OR AS A WHOLE  
 WITHOUT THE WRITTEN PERMISSION OF  
 Michael Byrne Mfg Co. IS PROHIBITED.

UNLESS OTHERWISE SPECIFIED:	NAME	DATE
DIMENSIONS ARE IN INCHES		
TOLERANCES:		
FRACTIONAL: 1/16	DRAWN	
ANGULAR: MATCH 5 BENDS	CHECKED	
ONE PLACE DECIMAL ±.02	ENG APPR.	
TWO PLACE DECIMAL ±.01	MFG APPR.	
THREE PLACE DECIMAL ±.005	G.A.	
MATERIAL:	Q.A.	
SEE BOM	MODEL:	
CUSTOMER		

**MICHAEL BYRNE MANUFACTURING**  
  
**Michael Byrne Mfg Co**  
 1855 Earthboring Rd.  
 Mansfield, Ohio 44903  
 www.byrnegroup.com  
 Phone : 419-525-1214 Fax : 419-525-2386

TITLE:  
**AUGER BORING MACHINE**  
 36-500 T4F

SIZE **D** DWG. NO. **BMD00-0001** REV **A**

DO NOT SCALE WEIGHT: 23328.43 SHEET 2 OF 2

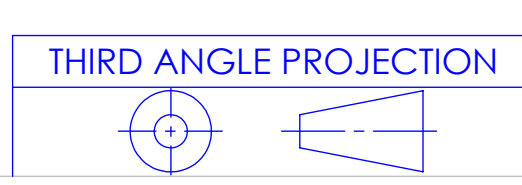

Y:\Solidworks\Auger Boring Machines TA\_ABM30-36 TA MAIN ASSEMBLY\_ABM30-36 TA